



DPEST 75 Power Entry Kit

Video: [Heat Cable Hardwire Tutorial](#)

Power Entry Seal Termination Kit for Self-Regulating Heating Cables

| Item | Description | Quantity |
|------|-------------------------------|----------|
| A | 1/8" x 3" Heat Shrink Tube | 2 |
| B | 1/2" x 3" Heat Shrink Tube | 1 |
| C | Lock Nut and Seal | 1 |
| D | 3/4" Entry Gland | 1 |
| E | Shrink End Cap | 1 |
| F | Un-Insulated Splice Connector | 1 |
| G | Yellow Wire Nuts | 2 |
| H | Warning Label | 1 |
| I | Mastic Tape | 2 |

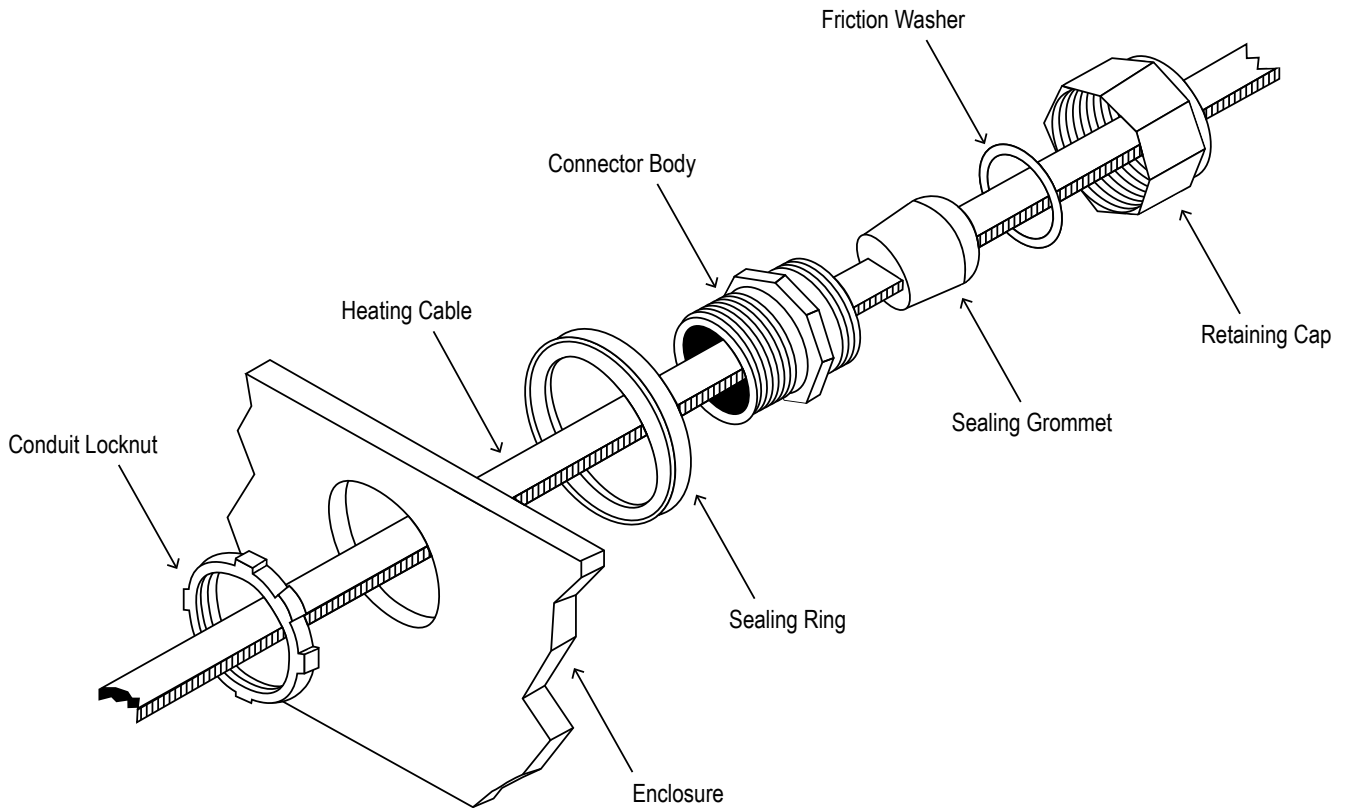
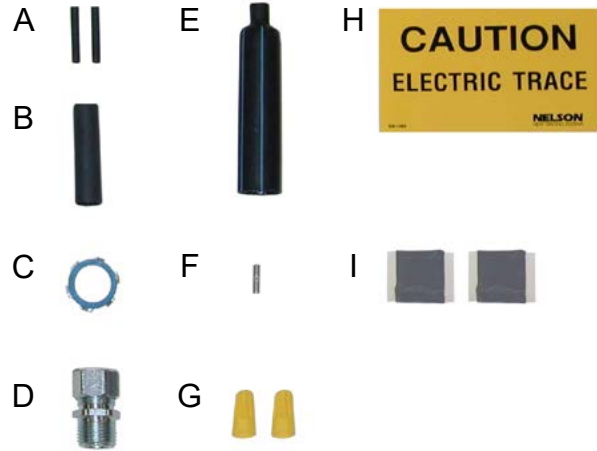

3/4" Entry Gland Part

1. Insert cable through retaining cap, friction washer, sealing grommet and connector body. As shown on previous page diagram.

Removing the Outer Jacket

1. 6" from the cable end, score the circumference of the cable outer jacket. Then score the outer jacket from the previous score toward the cable end. (FIG 1)
2. Flex the score points and remove the outer jacket, exposing the inner braid. (FIG 2)
3. Push the braid back toward the over jacket, creating a bulge in the braid.
4. Use a small screwdriver to create an opening in the braid near the original score point. (FIG 3)
5. Bend the heater cable over on itself creating an elbow.
6. Keeping the braid pushed towards the elbow, push the cable upward through the braid opening. After the cable is pushed through the braid, pull the braid tight. This will be the heater ground wire. (FIG 4)

Figure 1



Figure 2



Figure 3



Figure 4



Removing the INNER Jacket

7. Approximately 1/2" to 1" above the braid, score the circumference of the inner jacket. Then score the inner jacket from the previous score toward the cable end. Do not cut into the heater core. (FIG 5)
8. Remove inner jacket.
9. Once heater core is exposed. Cut a "V" notch. (FIG 6)
10. Using needle nose pliers, grab each bus wire at the V notch and using a twisting motion, pull the bus wire and the outer edge of heater material out away from the heater core material. Expose each wire down to the intact inner jacket. (FIG 7) NOTE: If the bus wires are hard to pull out use a blade to remove the black core from the side of the bus wires.
11. Once bus wires are exposed. Remove excess heater core material. (FIG 8)

Shrink Tube Procedures

12. Slide one 1/8" x 3" shrink tube (Item A) over each bus wire. Shrink with heat gun until tubing is completely shrunk.
13. Place 1/2" x 3" shrink tube (Item B) over both bus wires and the inner jacket and shrink down. (FIG 9) While still warm, using needle nose pliers, spread the bus wires apart and clamp between them, holding for 5 seconds. Ensure bare wires do not touch each other. (FIG 10)
14. Insert cable into junction box then add self sealing locknut to connection body.

Figure 5



Figure 6



Figure 7



Figure 8

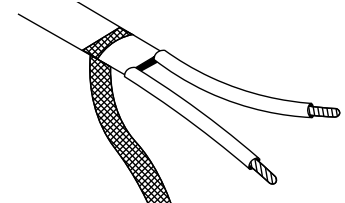

Figure 9

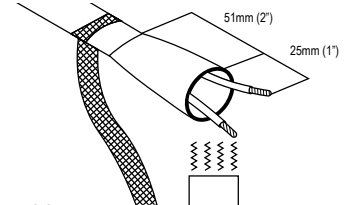

Figure 10

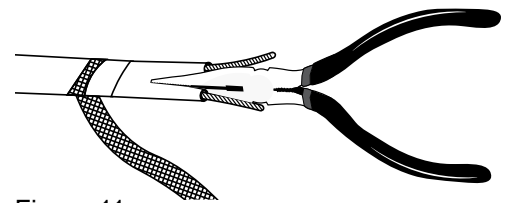
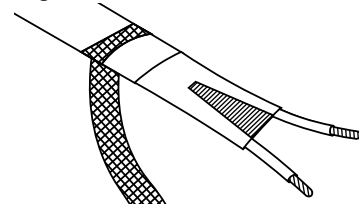

Figure 11



End Seal for Self-Regulating Cable

| Item | Description | Quantity |
|------|---------------------|----------|
| A | End Seal | 1 |
| B | Mastic Tape 2 Packs | 2 |



Removing the Outer Jacket

1. 2" from the cable end, score the circumference of the cable outer jacket. Then score the outer jacket from the previous score toward the cable end. (FIG 1)
2. Flex the score points and remove the outer jacket, exposing the inner braid.
3. Trim off all braided ground wires back to the outer jacket. (FIG 2)
4. Cut a "V" notch in the cable end. (FIG 3)
5. Using the mastic piece stretch and wrap the cable end. (FIG 4)
6. Slide the shrink end cap over the cable end covering the mastic wrap.
7. Heat until completely shrunk, and adhesive escapes the end cap. (FIG 5)

Figure 1



Figure 2



Figure 3



Figure 4



Figure 5

